

Architectural Hinges

NOVAS



Contents

- Introduction
- Hinge Data
- Ordering System
- Metric Hinges
- Imperial Hinges
- Heavy-Duty Butt Hinge
- Fast Fix/Liff Offs
- Aluminium Offset Pivot Set
- Hospital Escape Hinges



Introduction

Introduction

Nova Hardware Pty. Ltd. manufacture and market architectural and domestic quality hinges to Australia and other International markets, USA, UK and Asia. We also manufacture hinges for special applications. Please contact us if you have a requirement for non-standard products.

Hinge Data:

The hinge height is always the first measurement followed by the width and gauge. The height of the hinge is the length of the leaf, not including the tips of the pin. The width of a hinge is measured across both leaves when the hinge is fully opened.

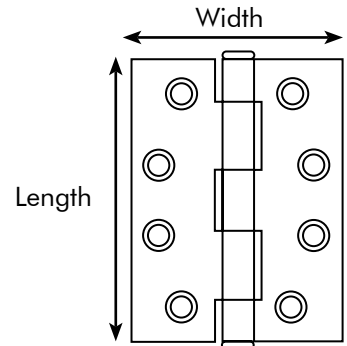

Loose Pin or Fixed Pin:

A Hinge supplied with Loose Pin means that the pin is capable of being removed for ease of fitting or later maintenance on the door. Loose Pin should never be used on exterior opening or security doors. In these circumstances for security reasons, fixed hinges or specifically designed security hinges should always be used.

Hinges Per Door:

As a general guide. Specify two hinges for average doors up to 2040mm in height. Doors over 2040mm and under 2340mm require three hinges. Doors over 2340mm and under 3050mm require four hinges. Doors fitted with door closers are subjected to greater forces and stresses than free hanging doors. The top hinge in particular suffers severe stress. Under these conditions it is recommended that a minimum of three hinges be used, the third hinge takes up the extra load and adds to the life of the installation. Under these conditions it is recommended that ball bearing or sinter lube bearing be used.

Hinge Selection Chart

Door Thickness	Door Width	Door Height	Recommended Hinge Numbers & Size	
			Metric Hinges	Imperial Hinges
30-45mm	Under 900mm	2040mm	2x 100x 75mm	2 x 4" x 3"
30-45mm	Under 900mm	Between 2040 & 2340	3x 100x 75mm	3 x 4" x 3"
		Between 2340 & 3000	3x 100x 100mm	3 x 4" x 4"
45-55mm	Under 1050mm	Between 2040 & 2340		3 x 4" x 4"
		Between 2340 & 3000		4 x 4.5" x 4"
65-65mm	Under 1250mm	Between 2040 & 2340		3 x 4.5" x 4.5"
		Between 2340 & 3000		4 x 4.5" x 4.5"

Hinge Numbering System

- Size
 1075: 100x75mm
 1010: 100x100mm
 1071: 100x71mm
 43: 4"x3"
 44: 4"x4"
 454: 4.5"x4"
 4545: 4.5"x4.5"

- FP: Fixed Pin
 LP: Loose Pin
 BB: Ball Bearing

- Finish
 SSS: Satin Stainless Steel
 PSS: Polished Stainless Steel
 SC: Satin Chrome
 CP: Polished Chrome
 ZP: Zinc Plated

- Blank: Woodscrew Only
 T/M: Half Woodscrew, Half Metal Threadal Screws.
 M/M: Metal Threadal Screws Only

101025BBFP-SSS-T/M



Metric Hinges

Button Tipped-Plain 100 x 75 x 2.5

Fixed Pin	Product Code	Finish
	107525BTFPSSS	SSS
	107525BTFPSS	PSS
	107525BTFPSC	SC
	107525BTFPZP	ZP
	107525BTFPZP	CP



Loose Pin

Product Code	Finish
107525BTLPSSS	SSS
107525BTLPPSS	PSS
107525BTLPSC	SC
107525BTLPZP	ZP
107525BTLPCP	CP

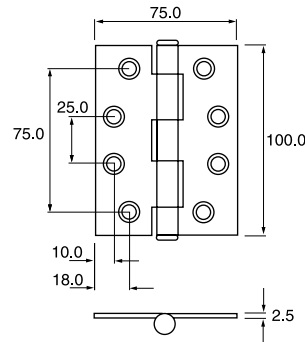

Button Tipped-Ball Bearing 100 x 75 x 2.5

Fixed Pin	Product Code	Finish
	107525BBFPSSS	SSS
	107525BBFPSS	PSS
	107525BBFPSC	SC



Loose Pin

Product Code	Finish
107525BBLPSSS	SSS
107525BBLPPSS	PSS
107525BBLPSC	SC

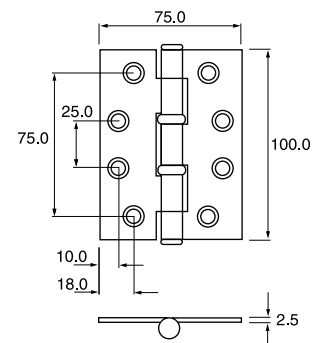

Metric Hinges

Button Tipped-Plain 100 x 100 x 2.5

Fixed Pin	Product Code	Finish
	101025BTFPSSS	SSS
	101025BTFPSS	PSS
	101025BTFPSC	SC
	101025BTFPZP	ZP
	101025BTFPCP	CP



Loose Pin

Product Code	Finish
101025BTLPSSS	SSS
101025BTLPSS	PSS
101025BTLPSC	SC
101025BTLPZP	ZP
101025BTLPCP	CP

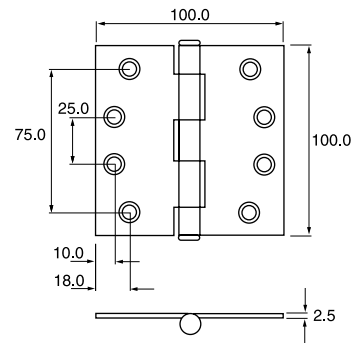

Button Tipped-Ball Bearing 100 x 100 x 2.5

Fixed Pin	Product Code	Finish
	101025BBFPSSS	SSS
	101025BBFPSS	PSS
	101025BBFPSC	SC



Loose Pin

Product Code	Finish
101025BBLPSSS	SSS
101025BBLPSS	PSS
101025BBLPSC	SC

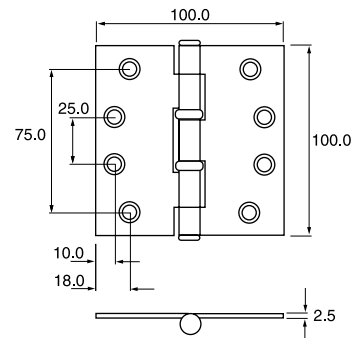

Imperial Hinges

Button Tipped Ball Bearing 4" x 3" x 3mm Fixed Pin

Product Code	Finish
433BBFP-SSS	SSS
433BBFP-PSS	PSS

Loose Pin

Product Code	Finish
433BBLP-SSS	SSS
433BBLP-PSS	PSS

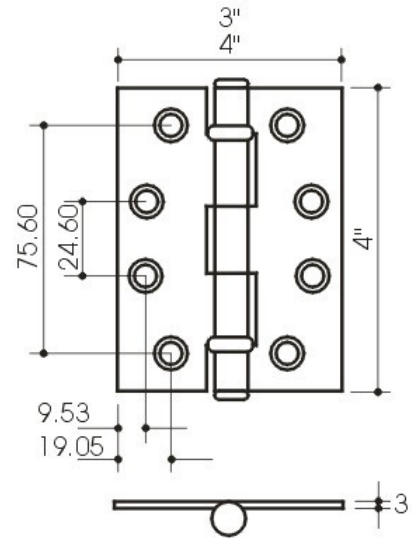

Button Tipped Ball Bearing 4" x 4" x 3mm Fixed Pin

Product Code	Finish
443BBFP-SSS	SSS
443BBFP-PSS	PSS

Loose Pin

Product Code	Finish
443BBLP-SSS	SSS
443BBLP-PSS	PSS

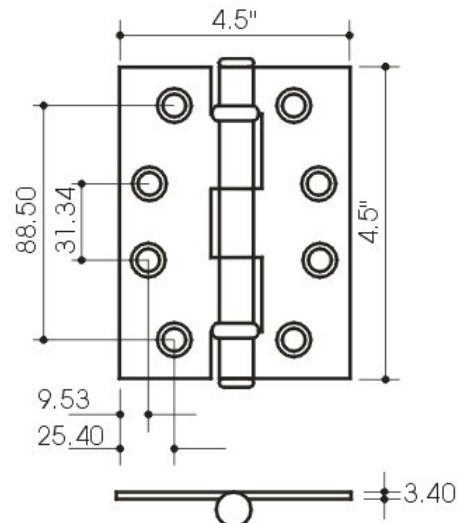

Button Tipped Ball Bearing 4.5" x 4.0" x 3.4mm Fixed Pin

Product Code	Finish
45434BBFP-SSS	SSS
45434BBFP-PSS	PSS

Loose Pin

Product Code	Finish
45434BBLP-SSS	SSS
45434BBLP-PSS	PSS
45434BBLP-SC	SC
45434BBLP-CP	CP

Button Tipped Ball Bearing 4.5" x 4.5" x 3.4mm Fixed Pin

Product Code	Finish
454534BBFP-SSS	SSS
454534BBFP-PSS	PSS

Loose Pin

Product Code	Finish
454534BBLP-SSS	SSS
454534BBLP-PSS	PSS
454534BBLP-SC	SC
454534BBLP-CP	CP



Heavy-duty Butt Hinge

4.5" x 4.5" x 4.7mm

Product Code	Finish
454547BBFP-SSS	SSS
454547BBFP-PSS	PSS

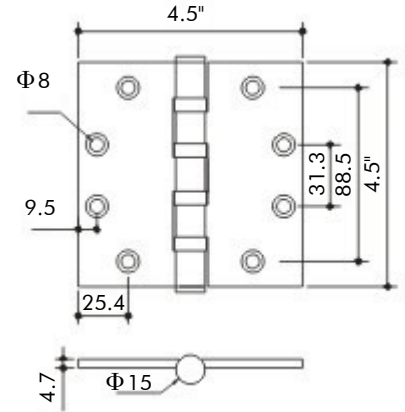

Fast Fix Hinge

100 x 71 x 2.5mm

Application
Aluminium/Metal Doors

Product Code	Finish
107125BBFF-SSS	SSS
107125BBFF-PSS	PSS

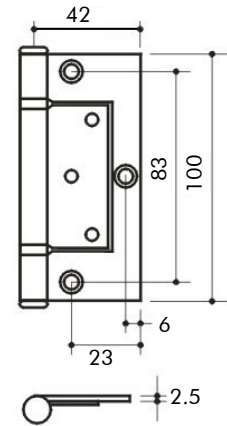

Lift-off Hinge/Zinc Plate

107516LOLZP	Left Hand	100 x 75 x 1.6mm
107516LORZP	Right Hand	100 x 75 x 1.6mm
107525LOLSS	Left Hand	100 x 75 x 2.5mm
107525LORSS	Right Hand	100 x 75 x 2.5mm

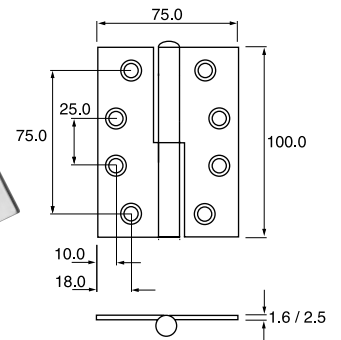

Aluminium Offset Pivot Set

Product Code	Finish
1811	Bronze
1811	Silver



Hospital Escape Hinge

Product Code	Finish
1810	SSS

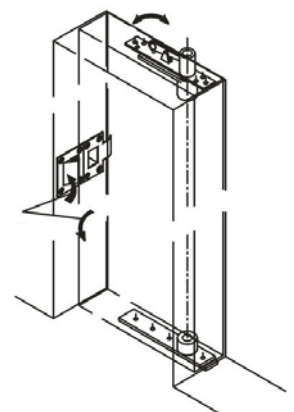

Contact Details

Shanghai Nova Hardware Co.,Ltd
402/Bld 4 No.1221 West Yan An Road,
Shanghai 200050,China
Phone: 86-21-6252 9138
Fax: 86-21-6252 7978
Email: sales@nova-hardware.com
Web: www.nova-hardware.com

Guarantee

Shanghai Nova Hardware Co.,Ltd guarantee all their products against defects in workmanship and materials subject to inspection and confirmation of fair wear and tear within the normal working life of the product.

Shanghai Nova Hardware Co.,Ltd assumes no liability for:

1. Improper installation or failure to follow fitting instructions.
 2. Product failure due to improper maintenance or unfair wear and tear.
 3. Indirect or consequential loss or damage.
 4. Cost of removal and/or replacement.
 5. Cost of freight and/or travelling expenses.
 6. Some plated finishes are classified as soft finishes. Deterioration is possible under some climatic conditions and cannot be unconditionally guaranteed.
- Consult your local Nova Representative or Agent for advice on all finishes.

